



Application

Control of up to three control circuits

- Control of a primary heat exchanger or boiler with up to two mixing heating circuit and one non-mixing heating circuit (both outdoor-temperature-compensated) and control of DHW heating in the secondary circuit
- Outdoor-temperature-compensated buffer storage tank control with up to two mixing heating circuits and continuous-flow hot water module
- Control of two outdoor-temperature-compensated heating circuits and a DHW heating with three valves in the primary circuit
- Control of three outdoor-temperature-compensated heating circuits with three valves in the primary circuit
- Applications with up to six control circuits are possible using optional TROVIS I/O expansion modules (linked by device bus).
- To control systems with larger numbers of control circuits, several controllers can be linked using a device bus.

Special features

- Rotary switch for direct access to the operating modes and key parameters of the control circuits
- Intuitive data retrieval and input by pressing and turning the pushbutton
- 365-day time switch with up to four time schedules and automatic summer time/winter time changeover; up to three times-of-use per day (input in steps of 15 minutes)
- Room panel to override operating mode and rated room temperature for each heating circuit
- Demand-driven control by set point demand by subsequent controllers over a device bus or using 0 to 10 V signal. The primary circuit controls the maximum flow temperature demand plus adjustable boost.
- Heating characteristics optionally based on the gradient or based on four points; variable return flow temperature limitation



Fig. 1: TROVIS 5578-E Heating and District Heating Controller

- Adaptation: automatic adaptation of the heating characteristic (room temperature sensor required)
- Optimization: calculation of the best possible activation and deactivation times for the heating (room temperature sensor required)
- Drying of jointless floors function with adjustable parameter settings
- Outputs AA1 to AA4 configurable (0 to 10 V signal to issue a control signal or request for required signal, PWM signal for pump speed control)
- Updatable flash memory in controller (operating system)
- Configuration and parameter settings in TROVIS-VIEW
- Alarms and setting changes including time stamp shown in tables
- Graphical display of operating values of the past 14 days at 1-minute intervals

Design and principle of operation

The TROVIS 5578-E Heating and District Heating Controller is adapted to the specific system by setting the appropriate system code number. Additional sensors and/or functions which are not part of the system's basic configuration can be selected over function blocks. The switch positions and entry of the key number allow access to the corresponding levels. For trained staff, the configuration levels used to set function blocks are indicated by "CO" and the parameter levels are indicated by "PA". Data is retrieved and entered at the heating and district heating controller using a rotary pushbutton (see Fig. 2). This process is facilitated by icons and plain text displayed on the LCD. The rotary switch is used to set the operating mode and the key parameters required for each circuit.

M-bus interface

A maximum of three meters conforming to EN 1434-3 can be connected for data transfer. In addition, heat meter WMZ1 for control circuit RK1, heat meter WMZ2 for control circuit RK2 and heat meter WMZ3 for control circuit RK3 are available for flow rate and/or capacity limitation. Various limits can be adjusted for the different operating modes "Heating control only", "Heating control with DHW heating" and "DHW heating only" in control circuit RK1. Outdoor-temperature-compensated flow rate or capacity limitation can also be implemented.

RS-485 interfaces

TROVIS 5578-1113 with galvanically isolated RS-485 interface for Modbus RTU or device bus communication or für multiplex mode (Modbus RTU and device bus communication over a shared RS-485 interface).

TROVIS 5578-1114 with two galvanically isolated RS-485 interfaces for separate Modbus RTU and device bus communication.

Ethernet interface

The Ethernet interface allows Modbus-TCP/IP communication and connection to SAM DISTRICT ENERGY

Bluetooth® interface

The TROVIS 55Pro (Android/iOS) app is available for changing parameter settings, saving configurations, firmware updates etc.

Mounting

For wall mounting, the base of the housing is screwed to the wall. After wiring the controller, the controller housing is placed on the back of the housing and fastened with two screws.

Two adjustable fixing clamps attached to the controller are used for panel mounting.

Operation

The heating controller is operated using the operating controls on the front. The rotary switch (see Fig. 3) is used to set the operating mode and the key parameters for each control circuit.

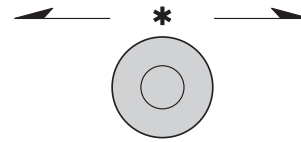

Turn [↻]:
Select readings, parameters and function blocks

Press [*]:
Confirm adjusted selection or settings

Fig. 2: Rotary pushbutton

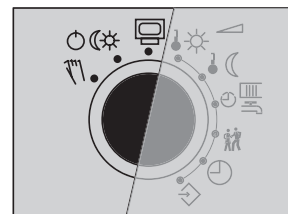

☰ Information level

☀/☾ Operating modes

👤 Manual level

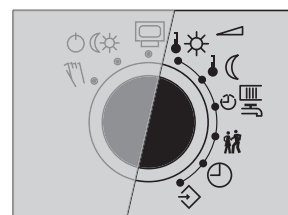

☀ Day set point (rated room temperature)

☾ Night set point (reduced room temperature)

📅 Times-of-use for heating/DHW

👤 Special time-of-use

🕒 Time/date

⚙ Settings

Fig. 3: Switch positions and their meaning

Electrical connection

The controller consists of the housing containing the electronics and a separate base with terminals for electrical connection. Two wires with a cross-section of max. 1.5 mm² can be connected to each terminal. The sensor connection lines must be installed separately from the lines carrying the power supply.

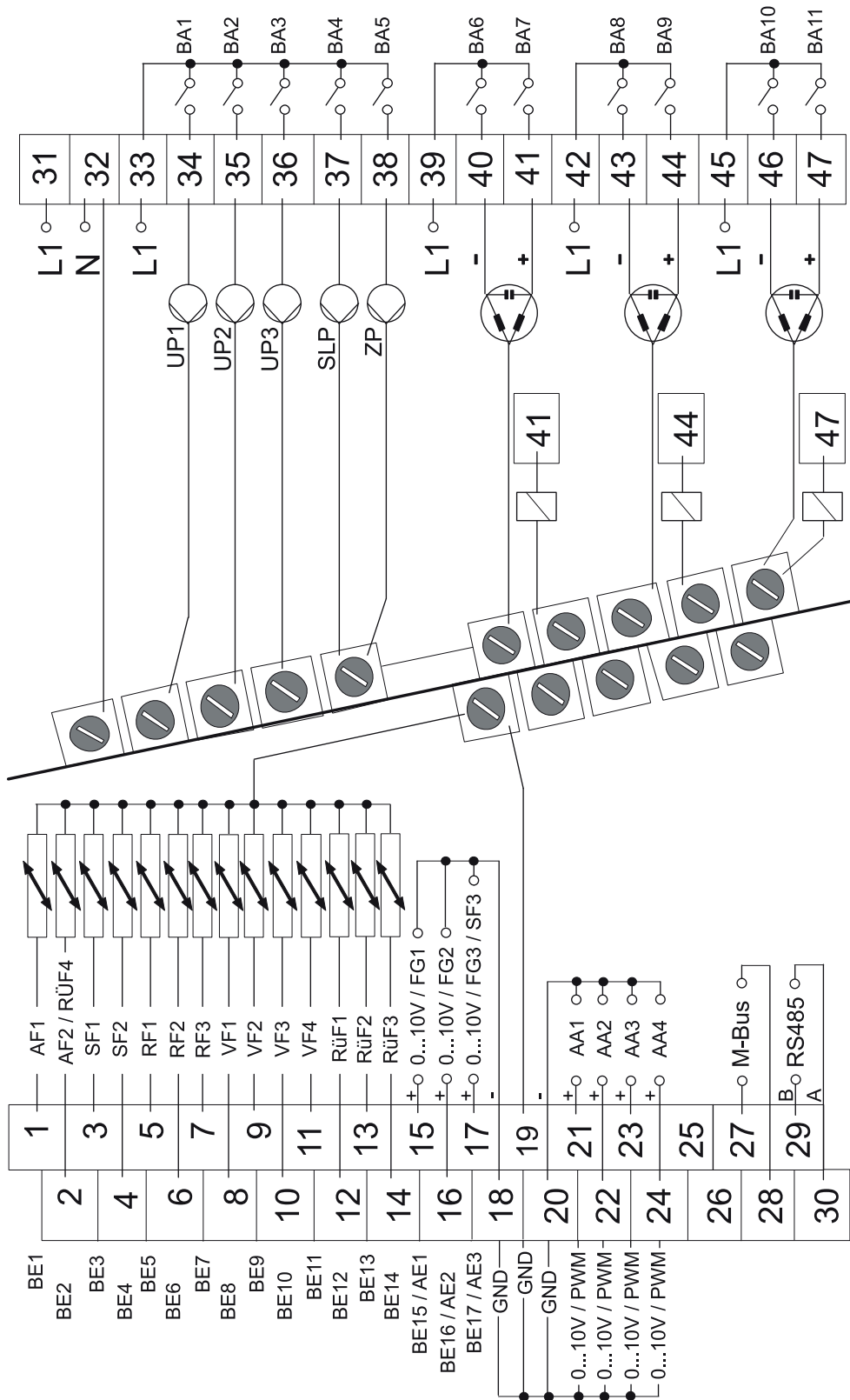

Fig. 4: Electrical connection of the TROVIS 5578-1113 Heating Controller

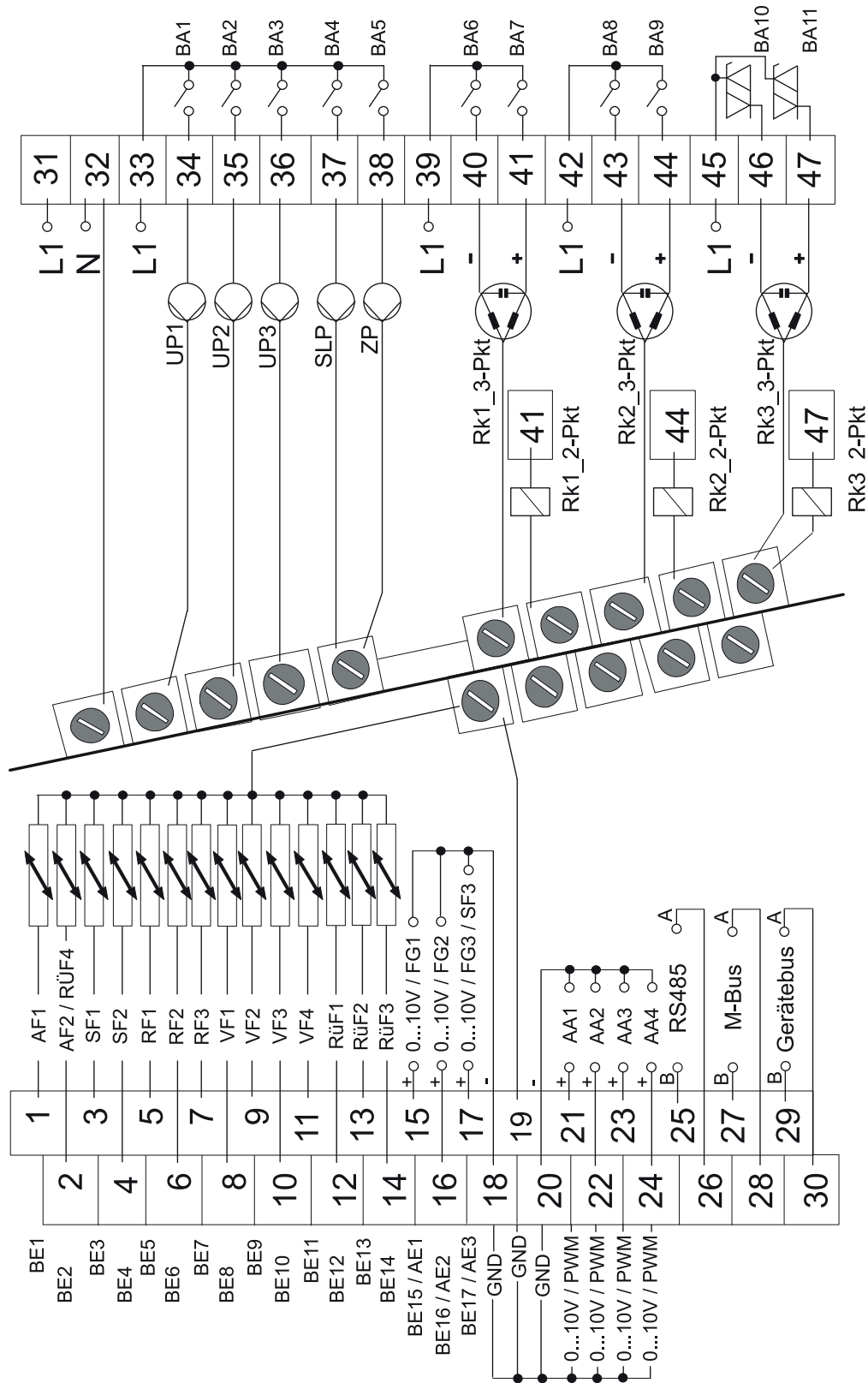

Fig. 5: Electrical connection of the TROVIS 5578-1114 Heating Controller

Legend:

- | | | | | | |
|----|----------------|-----|------------------------|-----|----------------------------|
| AA | Analog output | FG | Potentiometer | SF | Storage tank sensor |
| AE | Analog input | PWM | Pulse width modulation | SLP | Storage tank charging pump |
| AF | Outdoor sensor | RF | Room sensor | UP | Circulation pump (heating) |
| BA | Binary output | RK | Control circuit | VF | Flow sensor |
| BE | Binary input | RÜF | Return flow sensor | ZP | Circulation pump (DHW) |

Technical data

Inputs	14x Pt 1000, PTC or Ni 1000 sensor inputs, alternatively configurable for binary alarms, 3x inputs for 0 to 10 V Input 17 for a pulse signal (3 to 800 pulses/h) of a heat meter for capacity limitation in RK1
Outputs	3x three-step signal, alternatively 3x on/off signal 5578-1113: relay outputs, rating max. 250 V AC, 2 A 5578-1114: RK1, RK2: relay outputs, rating max. 250 V AC, 2 A; RK3: TRIAC output, rating max. 250 V AC, 0.12 A 5x pump output: relay outputs, rating max. 250 V AC, 2 A All relay outputs with varistor suppression 4x 0 to 10 V or PWM signal, configurable, to issue a control signal or for pump speed control, load >5 kΩ
TROVIS 5578-1113	Galvanically isolated RS-485 interface for Modbus-RTU and device bus communication. Data format Modbus RTU: 8N1 Bluetooth [®] interface 4.1
TROVIS 5578-1114	2x galvanically isolated RS-485 interface for Modbus-RTU and device bus communication. Data format Modbus RTU: 8N1 Bluetooth [®] interface 5.0
Interfaces	Ethernet interface for Modbus-TCP/IP communication and connection to SAM DISTRICT ENERGY using an Internet router Alternative access using optional external gateways M-bus interface for up to three M-bus units, protocol acc. to EN 1434-3
Supply voltage	165 to 250 V, 48 to 62 Hz, max. 10 VA
Ambient temperature	0 to 40 °C (operation), -10 to +60 °C (storage and transport)
Degree of protection	IP 40 according to EN 60529
Class of protection	II according to EN 61140
Degree of contamination	2 according to EN 61010-1
Overvoltage category	II according to EN 60664
Noise immunity	According to EN 61000-6-1
Noise emission	According to EN 61000-6-3
Conformity	CE
Weight	Approx. 0.5 kg

Dimensions

Panel cut-out 138 x 92

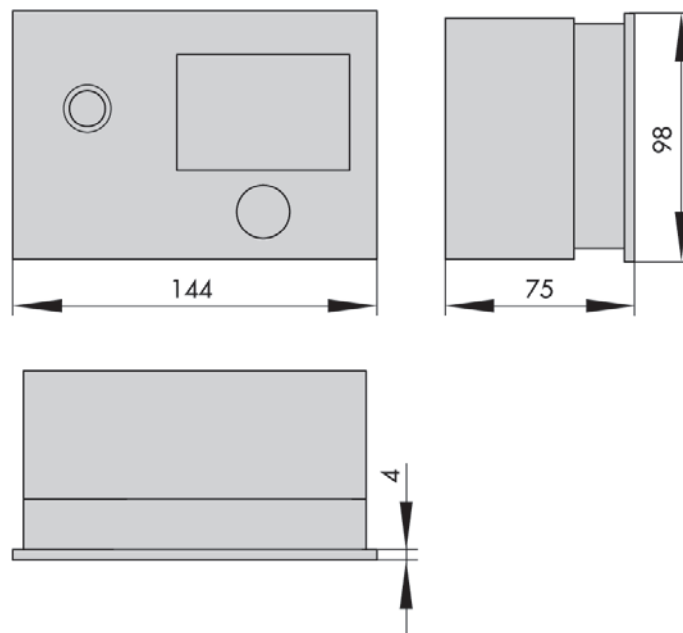

Fig. 6: Dimensions in mm

Accessories

Surge arrester SA5000	Order no. 1400-9868
TROVIS I/O (expansion module)	Order no. 100062999
SAM MOBILE Gateway	Type 5655
Sensors and room panels	▶ T 5200 (Information Sheet: Temperature Sensors and Thermostats)
TROVIS-VIEW software (free of charge)	▶ www.samsongroup.com > SERVICE & SUPPORT > Downloads > TROVIS-VIEW
SAM DISTRICT ENERGY	▶ www.samsongroup.com > Products & Applications > Digital solutions > SAM DISTRICT ENERGY ▶ EB 6901

Ordering text

TROVIS 5578-E Heating and District Heating Controller

Associated mounting and operating instructions

- For TROVIS 5578-E: ▶ EB 5578-E
- For TROVIS-VIEW: ▶ EB 6661