

Data sheet

MULTICAL® 303

All-round heat and cooling meter, easy to install and easy to use

- Fully programmable data logger with minute logger
- Configurable M-Bus and Wireless M-Bus with logger reading
- On-site configurable between inlet and outlet
- Dynamic range of up to 1500:1 from start to saturation flow
- Low pressure loss – all flow sizes below 0.1 bar
- PN16/PN25 metal flow sensor – approved for up to 130 °C
- Battery lifetime of up to 16 years
- 7- or 8-digit display resolution



MID 2014/32/EU



EN 1434

DK-BEK 1178 – 06/11/2014



EN 1434

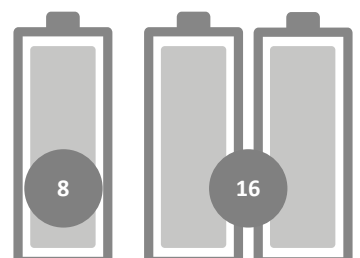

Contents

Description	3
Mechanical data	4
Approved meter data	5
Accuracy	6
Pressure loss	7
Dimensioned sketches	8
Electrical data	10
Product variants	11
Meter configuration	12
Information codes in display	13
Accessories	14

Description

Application

MULTICAL® 303 is the compact all-round heat and cooling meter that can be installed everywhere due to its minimum dimensions. The meter can be turned during installation, even in the most compact systems, enabling you to always obtain optimal reading of the display.

The robust metal flow sensor tolerates continuous temperatures of up to 130 °C, is effectively protected against condensation and can be used in both PN16 and PN25 installations.

The flow sensor is constructed with Kamstrup's unique ultrasonic technique that ensures an extremely long lifetime – also in magnetite-containing heating systems.

Functionality

MULTICAL® 303 consists of a flow sensor based on ultrasound, an electronic display unit and a Pt500 sensor set. These components are separately calibrated and then assembled to one heat, cooling or combined heat/cooling meter. If the components are separated, a reverification of the meter is required.

The meter has built-in, programmable data logger that stores all relevant registers. Standard data logger registers are stored for 20 years, 36 months, 460 days and 1400 hours.

During installation, the meter can be configured for installation of the flow sensor in either inlet or outlet pipe. Furthermore, the energy unit and resolution as well as date/time and M-Bus address can be adjusted merely by pressing a button – no special tools needed.

M-Bus or Wireless M-Bus

MULTICAL® 303 can be delivered with factory-mounted cable for M-Bus or with Wireless M-Bus in mode C1 or T1 according to EN 13757.

The M-Bus communication is galvanically separated and has auto-select 300/2400 baud, primary/secondary addressing and collision detection. The current consumption is 1 unit load, and separate registers for heat and cooling energy are read.

The Wireless M-Bus data communication follows the European standard EN 13757, and the data telegram is configurable for either mode C1, T1/C1 BSI or T1/C1 OMS. The data communication is 128 bit AES-encrypted.

Mechanical data

Ambient temperature	5...55 °C. Non-condensing, closed location (indoor installation)
Protection class	
- Calculator	IP65
- Flow sensor	IP68
Media temperatures	
- Heat meters 303-W	2...130 °C
- Cooling meters 303-C	2...50 °C
- Heat/cooling meters 303-T	2...130 °C
Medium in flow sensor	Water (district heating water as described in AGFW FW510)
Storage temperature	-25...60 °C (drained flow sensor)
Pressure stage	PN16/PN25, PS25
Weight	From 0.7 to 0.8 kg depending on the flow sensor size
Flow sensor cable	1.5 m (the cable is non-detachable)
Temperature sensor cables	1.5 m or 3 m (the cables are detachable, reverification required)

At media temperatures below the ambient temperature or above 90 °C, wall-mounting of the calculator is recommended.

Materials

Wetted parts	
- Flow sensor casing	Hot forged, dezincification-resistant brass (CW 602N)
- Transducer	Stainless steel, w.nr. 1.4404
- O-rings	EPDM
- Measuring tube	Thermoplastic, PES 30 % GF
- Reflectors	Thermoplastic, PES 30 % GF and stainless steel, w.nr. 1.4306
Flow sensor cover	Thermoplastic, PC 20 % GF
Wall bracket	Thermoplastic, PC 20 % GF
Calculator casing	
- Top	Thermoplastic, PC 10 % GF with TPE (thermoplastic elastomer)
- Base	Thermoplastic, PC/ABS
Cables	
- Flow sensor	Silicone cable with inner Teflon insulation
- Temperature	Silicone cable with inner Teflon insulation
- M-Bus	PVC cable

Approved meter data

Approvals		
- Heat meter	DK-0200-MI004-045	The stated minimum temperatures only relate to the type approval. The meter has no cut-off for low temperature and thus measures down to 0.01 °C and 0.01 K.
- Temperature range	θ : 2 °C...180 °C	
- Differential range	$\Delta\theta$: 3 K...178 K	
- Cooling meter	TS 27.02 015	
- Temperature range	θ : 2 °C...180 °C	
- Differential range	$\Delta\theta$: 3 K...178 K	
- Bifunctional heat/cooling meter	Marked with DK-0200-MI004-045 and TS 27.02 015 as well as MID year mark	
- Temperature range	θ : 2 °C...180 °C	
- Differential range	$\Delta\theta$: 3 K...178 K	
Standards and norms	EN 1434:2015, prEN 1434:2020 and BEK1178	
EU directives	Measuring Instruments Directive Low Voltage Directive Electromagnetic Compatibility Directive Radio Equipment Directive RoHS Directive Pressurised equipment Directive	
EN 1434 designation	Environmental class A	
MID designation		
- Mechanical environment	Class M1 and M2	
- Electromagnetic environment	Class E1	
Temperature sensor connection		
- Type 303-W/C/T	Pt500 – EN 60751, 2-wire connection (the cables are detachable, reverification required)	

Type number	Nom. flow q_p [m ³ /h]	Max flow q_s [m ³ /h]	Min. flow		Dynamic range		"Min. flow cut-off" [l/h]	Saturation flow [m ³ /h]	Pressure loss Δp @ q_p [bar]	Threaded connection on meter	Length [mm]
			100:1 q_i [l/h]	250:1 q_i [l/h]	$q_p:q_i$	$q_p:q_i$					
303-x-10	0.6	1.2	6	-	100:1	-	3	1.5	0.03	G½B	110
303-x-40	1.5	3	15	6	100:1	250:1	3	4.6	0.09	G½B	110
303-x-70	1.5	3	15	6	100:1	250:1	3	4.6	0.09	G1B	130
303-x-A0	2.5	5	25	10	100:1	250:1	5	7.6	0.09	G1B	130

Accuracy

Meter components	MPE according to EN 1434-1	MULTICAL® 303, typical accuracy
Flow sensor	$E_f = \pm [2 + 0.02 q_p/q] \%$	$E_f = \pm [1 + 0.01 q_p/q] \%$
Calculator	$E_c = \pm [0.5 + \Delta\Theta_{min.}/\Delta\Theta] \%$	$E_c = \pm [0.15 + 2/\Delta\Theta] \%$
Sensor set	$E_t = \pm [0.5 + 3 \Delta\Theta_{min.}/\Delta\Theta] \%$	$E_t = \pm [0.4 + 4/\Delta\Theta] \%$

Total typical accuracy of MULTICAL® 303 compared to EN 1434-1

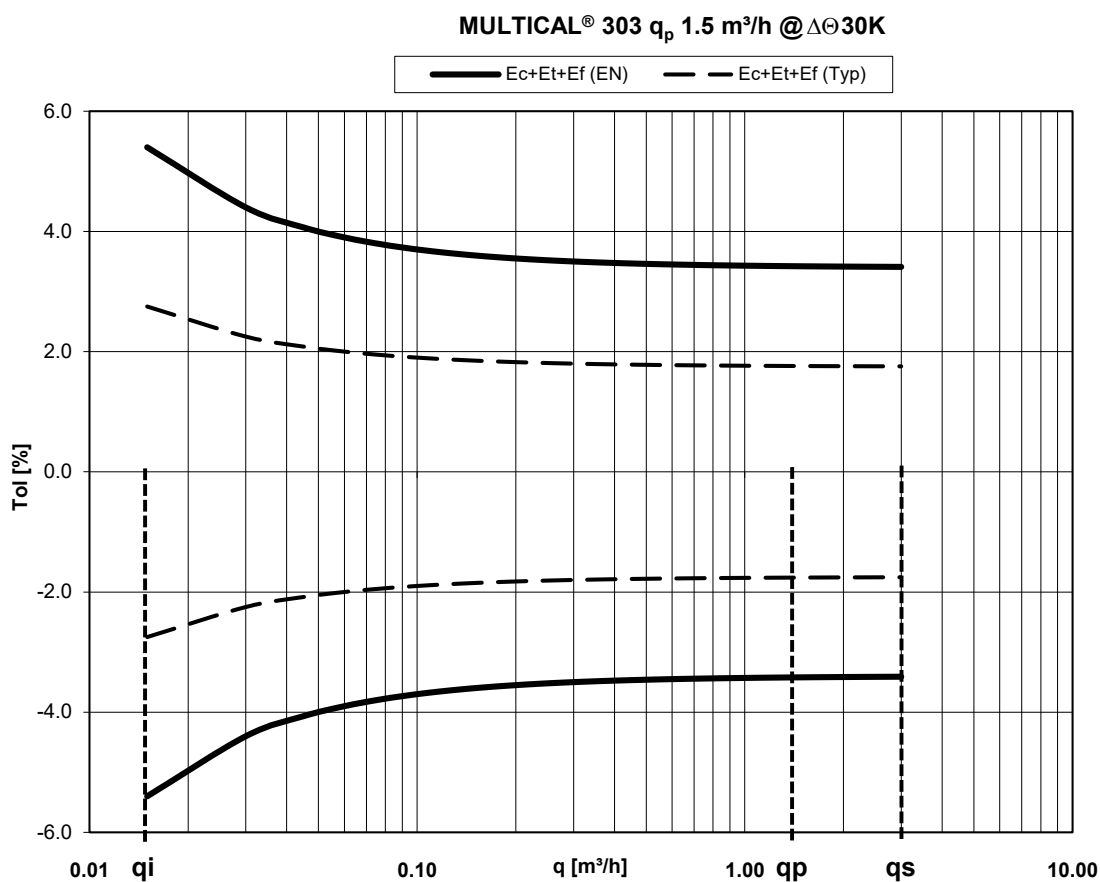

Pressure loss

The pressure loss in a flow sensor is stated as the maximum pressure loss at q_p .
 According to EN 1434, the maximum pressure loss must not exceed 0.25 bar.

Graph	q_p [m³/h]	Installation dimen- sions	Nom. diameter [mm]	$\Delta p@q_p$ [bar]	k_v	$q@0.25\text{ bar}$ [m³/h]
A	0.6	G¾B x 110 mm	DN15	0.03	3.46	1.7
B	1.5	G¾B x 110 mm	DN15	0.09	4.89	2.4
B	1.5	G1 x 130 mm	DN 20	0.09	4.89	2.4
C	2.5	G1 x 130 mm	DN 20	0.09	8.15	4.1

Δp MULTICAL® 303

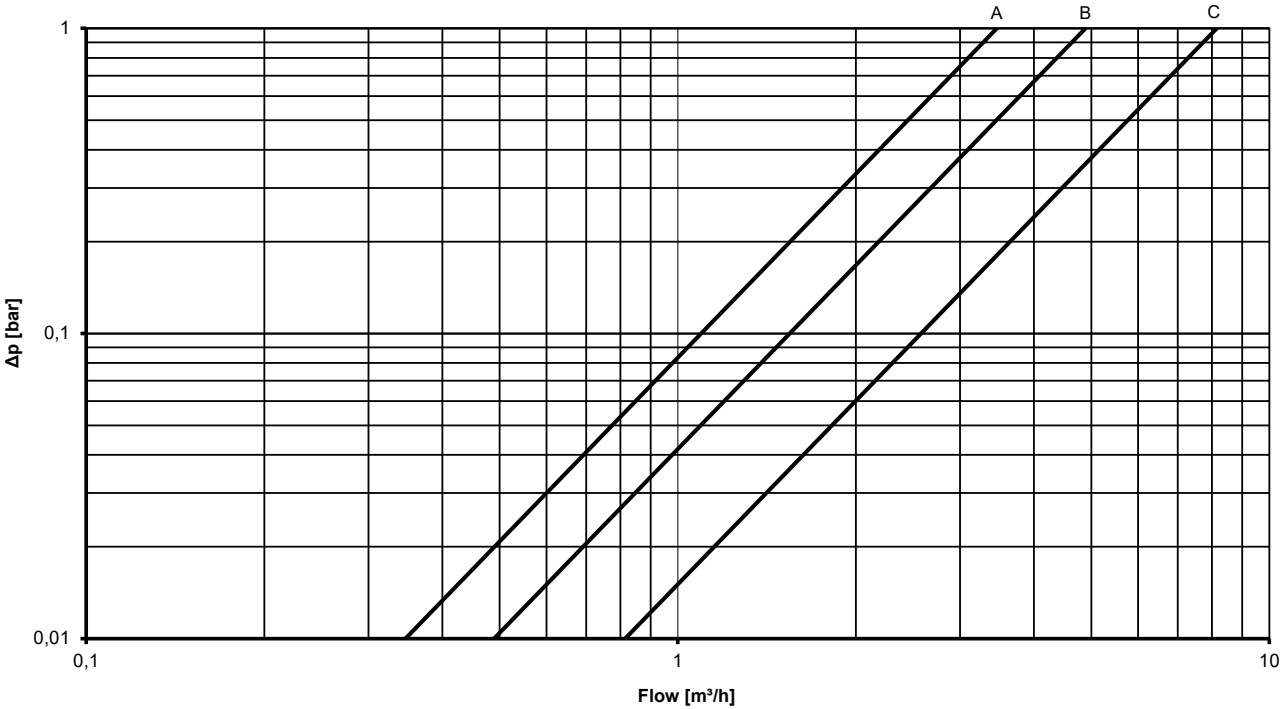

Dimensioned sketches

All measurements in [mm]

Calculator

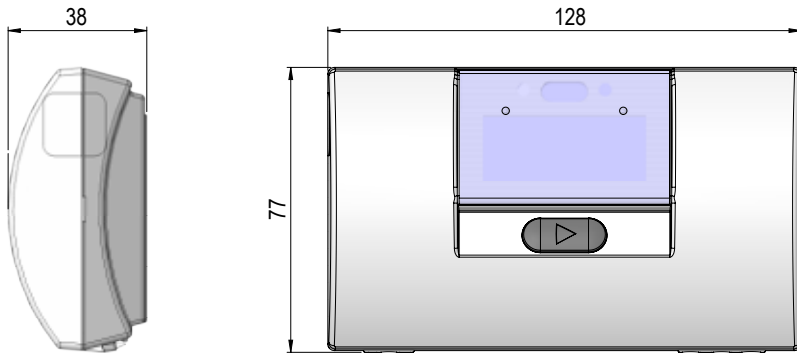

Complete MULTICAL® 303 with calculator mounted on flow sensor

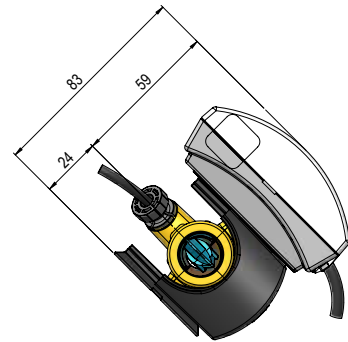

Calculator mounted with wall bracket

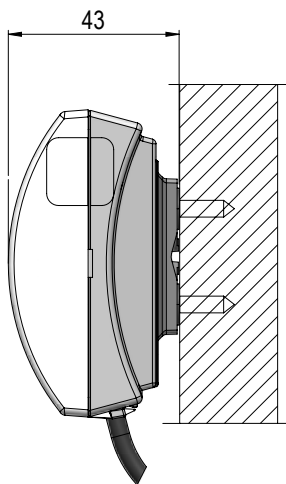

Wall bracket for calculator

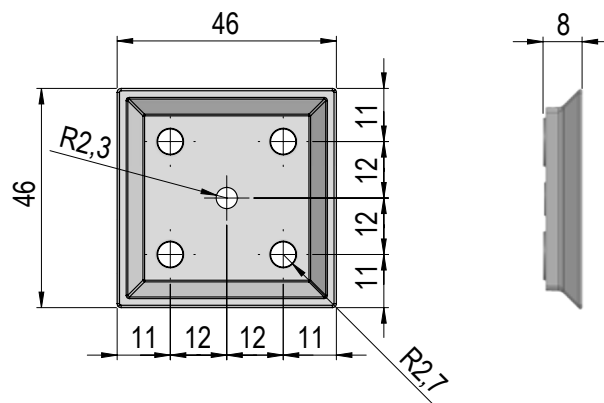

Dimensioned sketches

Direct short temperature sensor

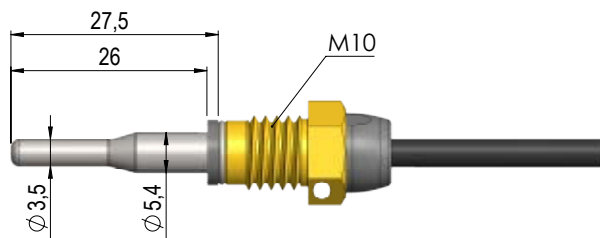

Pocket temperature sensor with composite union

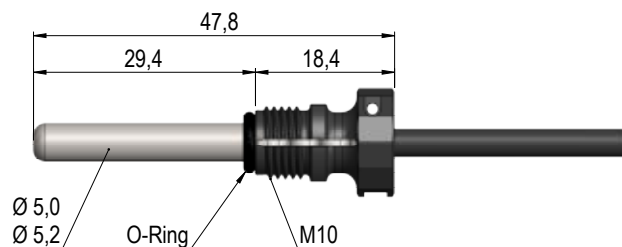

Flow sensor

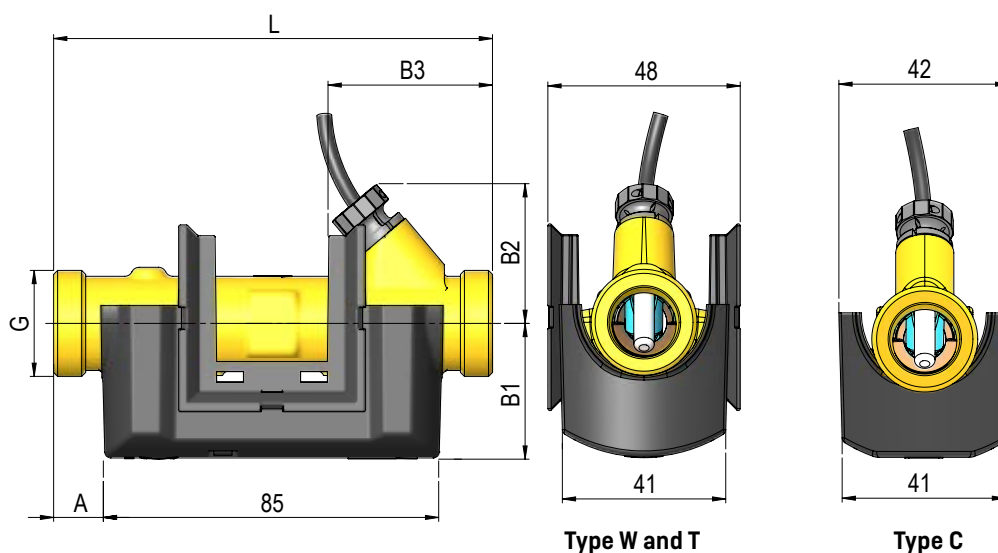

Thread	L [mm]	A [mm]	B1 [mm]	B2 [mm]	B3 [mm]	Approx. weight [kg] *
G½B [R½]	110	12	35	35	40	0.7
G1B [R¾]	130	22	38	38	50	0.8

* The weight indication includes the complete meter including flow sensor, calculator, sensor set and 2 x A-batteries. Any provided accessories such as couplings, nipples and sensor pockets as well as packaging are not included in the weight indication.

Electrical data

Calculator data

Display	LCD – 7 or 8 digits with a digit height of 6.8 mm	
Resolution	9999.999 – 99999.99 – 999999.9 – 9999999 99999.999 – 999999.99 – 9999999.9 – 99999999	
Energy units	MWh – kWh – GJ	
Data logger (EEPROM)		
- Logger contents	Programmable - all registers can be selected	
- Logging interval	Programmable - from 1 minute to 1 year	
- Logging depth	Programmable - standard: 20 years, 36 months, 460 days, 1400 hours (RR-code = 10)	
Info logger (EEPROM)	50 info codes (50 latest are shown in the display)	
Clock/calendar	Clock, calendar, leap year compensation, target date	
Daylight saving time/wintertime (DST)	Programmable The function can be disabled so that "technical normal time" is used	
Clock accuracy	Without external adjustments: Less than 15 minutes/year With external adjustment every 48 hours: Less than 7 s from legal time	
Data communication	KMP protocol with CRC16 is used for optical communication	
M-Bus	Protocol according to EN 13757-3:2018, 300 and 2400 baud communication speeds with automatic baudrate detection. Current consumption: 1 unit load (1.5 mA). Fixed 2-wire cable. Polarity independent.	
Wireless M-Bus	Mode C1 protocol according to EN 13757-4:2019. Individual 128 bit AES-encryption. Transmission interval: 16 s. / 96 s. / 15 m. Transmission frequency: 868.95 MHz Mode T1/C1 BSI protocol according to EN13757-4:2019 and OMS Specification Volume 2 issue 4.2.1. Individual 128 bit AES encryption, security profile B. Transmission interval: 16 s. / 96 s. / 15 m. Transmission frequency: 868.95 MHz Mode T1/C1 OMS protocol according to EN13757-4:2019 and OMS Specification Volume 2 issue 4.2.1. Individual 128 bit AES encryption, security profile A. Transmission interval: 16 s. / 96 s. / 15 m. Transmission frequency: 868.95 MHz	
Power in temperature sensors	< 0.4 μ W RMS "normal mode" / < 2 μ W RMS "fast mode"	
Supply voltage	3.65 VDC \pm 0.1 VDC	
EMC data	Complies with EN 1434 class A (MID class E1)	
Battery	3.65 VDC, 1 x A-cell lithium	3.65 VDC, 2 x A-cell lithium
Life*	Up to 8 years @ $t_{BAT} < 30$ °C	Up to 16 years @ $t_{BAT} < 30$ °C
Lithium contents	Approx. 0.9 g	2 x approx. 0.9 g
Transport category	Not included in the rules of dangerous goods	

* The battery lifetime is affected by the meter's communication and setup parameters as well as transmission interval, transmission power and datagram contents.

Product variants

MULTICAL® 303 type number	Static data Written on the front of the meter 303-x-xx-x-xx				Dynamic data Shown in the display xx-x-xx			
	Type 303	<input type="checkbox"/>	<input type="checkbox"/>	<input type="checkbox"/>	<input type="checkbox"/>	<input type="checkbox"/>	<input type="checkbox"/>	<input type="checkbox"/>
Sensor connection								
Pt500 Heat meter	W							
Pt500 Heat/cooling meter	T							
Pt500 Cooling meter	C							
Flow sensor¹⁾								
q_p [m ³ /h]	Connection	Length [mm]	Dynamic range					
0.6	G½B (R½)	110	100:1	10				
1.5	G½B (R½)	110	100:1	40				
1.5	G1B (R¾)	130	100:1	70				
2.5	G1B (R¾)	130	100:1	A0				
Meter type								
Heat meter (MID module B+D)				2				
Heat/cooling meter (MID module B+D & TS27.02+DK268) ²⁾	θ_{hc} = OFF			3				
Heat meter, National approvals				4				
Cooling meter (TS27.02+DK268)				5				
Heat/cooling meter (MID module B+D & TS27.02+DK268) ²⁾	θ_{hc} = ON			6				
Country code								
Determined by Kamstrup upon receipt of order								XX
Temperature sensor set (Pt500)								
	Length [mm]	Diameter Ø [mm]	Cable length [m]					
Direct short temperature sensors	27.5	-	1.5	51				
Direct short temperature sensors	27.5	-	3.0	52				
Ø5.0 with composite unions	-	5.0	1.5	61				
Ø5.0 with composite unions	-	5.0	3.0	62				
Ø5.2 with composite unions	-	5.2	1.5	71				
Ø5.2 with composite unions	-	5.2	3.0	72				
Supply³⁾								
Battery, 1 x A-cell	Battery lifetime of up to 8 years			1				
Battery, 2 x A-cells	Battery lifetime of up to 16 years			9				
Communication								
M-Bus, configurable								20
Wireless M-Bus, configurable 868.95 MHz EU								30

1) The flow sensors are type-approved for the dynamic ranges $q_p; q_i = 250:1$ and $100:1$, but are as standard delivered as $100:1$. Please contact Kamstrup A/S for further information.

2) In some countries bi-functional meters type 3 and 6 are only allowed to be assigned with the MID marking, due to national law.

3) The battery lifetime is affected by the meter's communication and setup parameters as well as transmission interval, transmission power and datagram contents.

MULTICAL® 303

Please contact Kamstrup A/S for calculations of specific configurations.

Meter configuration

	A	B	CCC	DDD	L	RR	T	VVVV	XXX	YY	ZZZ
Flow sensor position											
Inlet	3										
Outlet	4										
Measure											
GJ	2										
kWh	3										
MWh	4										
Flow sensor coding											
Normal/high resolution (7 digits)			4xx								
High resolution (8 digits)			5xx								
Display											
Heat meter				210							
Heat/cooling meter				310							
Cooling meter				510							
Integration mode											
Adaptive mode (4-64 s)					5						
Normal mode (32 s)					6						
Fast mode (4 s)					7						
Data logger profile											
Standard data logger profile						10					
Encryption level											
Individual key							3				
Customer label											
Serial number								XXXX			
Communication configuration											
Communication hardware											
M-Bus (selection in type number)									x20		
Wireless M-Bus (selection in type number)									x30		
System configuration (wM-Bus)											
See the technical description - 5512-2701										YY	
Datagram (M-Bus/wM-Bus)											
See the technical description - 5512-2701											ZZZ

Please contact Kamstrup A/S for further information on configuration options.

Information codes in display

Display digit								Description
1	2	3	4	5	6	7	8	
Info	t1	t2	0	V1	0	0	0	
1								Supply voltage is missing
2								Low battery level
	1							t1 above measuring range or disconnected
		1						t2 above measuring range or disconnected
	2							t1 below measuring range or short-circuited
		2						t2 below measuring range or short-circuited
	9	9						Invalid temperature difference (t1-t2)
				3				V1 Air
				4				V1 Wrong flow direction
				6				V1 > q _s for more than one hour
Example:								
1	0	2	0	0	0	0	0	

Note: Infocodes are configurable. It is thus not certain that all parameters are available in a given MULTICAL® 303. An info logger stores the info code each time the info code is changed. It is possible to read the latest 50 changes of the info code as well as the date of the change.

Accessories

Type number	Description
3026-655.A	Wall bracket including rawlplugs and screws
6699-099	Infrared optical read-out head with USB plug
6696-005	Optical read-out head with Bluetooth
3026-909	Holder for optical read-out head
669-042	Metal plate for optical read-out head, 20 pcs.
3130-262	Blind plug including O-ring for the temperature sensor connecting in the flow sensor
2210-061	Gasket for flow sensor G $\frac{3}{4}$ B (R $\frac{1}{2}$) / coupling 6561-323
2210-062	Gasket for flow sensor G1B (R $\frac{3}{4}$) / coupling 6561-324
2105-002	Sealing cap for flow sensor G $\frac{3}{4}$ B (R $\frac{1}{2}$), blue
3026-1148	Sealing cap for flow sensor G $\frac{3}{4}$ B (R $\frac{1}{2}$), self-locking, blue
6556-491	R $\frac{1}{2}$ - M10 nipple for direct short temperature sensor
6556-492	R $\frac{3}{4}$ - M10 nipple for direct short temperature sensor
6556-474	G $\frac{1}{2}$ B ball valve with M10x1 sensor socket, 48 mm
6556-475	G $\frac{3}{4}$ B ball valve with M10x1 sensor socket, 54 mm
3026-517	Sealing cap for direct short temperature sensor DS27,5, blue
3026-518	Sealing cap for direct short temperature sensor DS27,5, red
3026-1034	Sealing cap for Ø5.0 mm / Ø5.2 mm temperature sensor with composite union, black

For further information on MULTICAL® 303, please refer to the technical description, which you can find on [Kamstrup Product Centre](#).

Accessories

2 couplings including gaskets

Article number	Size	Nipple	Union
6561-323	DN15	R½	G¾B
6561-324	DN20	R¾	G1B

Material

Copper alloy brass, CW617N [nipple]

Copper alloy brass, CW602N [union]

Extension piece

Article number	Description	Length [mm]	Total length [mm]
1330-010	Extension including gaskets, 110 - 165 mm, G¾B - G1B, 1 pc. ¹⁾	55 ²⁾	165 ²⁾
1330-012	Extension including gaskets, 110 - 220 mm, G¾B - G1B, 1 pc. ¹⁾	110 ²⁾	220 ²⁾
1330-013	Extension including gaskets, 110 - 130 mm, G¾B - G1B, 1 pc. ¹⁾	20 ²⁾	130 ²⁾
1330-015	Extension excluding gaskets, 110 - 130 mm, G¾B - G¾B, 1 pc.	20	130
1330-019	Extension excluding gaskets, 110 - 165 mm, G¾B - G¾B, 1 pc.	55	165

1) Order 2 pcs. per meter

2) Total length with 2 extension pieces

Material

Copper alloy brass, CW614N

MULTICAL® 303

Kamstrup A/S

Industrivej 28, Stilling
DK-8660 Skanderborg
T: +45 89 93 10 00
info@kamstrup.com
kamstrup.com