



#### Application

Electric actuator designed for valves used in heating, ventilation and air-conditioning systems as well as in process engineering and industrial energy transfer systems.

#### Special features

The linear actuator is particularly suitable for attachment to SAMSON Types 3260, 3222, 3226, 3213, 3214 and V2001 Valves. In addition, it can be used as additional electric actuators on self-operated differential pressure and flow regulators.

- Actuator with or without fail-safe action
- Motor switched off by torque switches
- Manual override (handwheel, only version without fail-safe action)
- No maintenance

#### Versions

- Three-step version
  - Synchronous motor with maintenance-free gearing
- Digital positioner
  - Stepper motor with maintenance-free gearing
  - Adjustment of the direction of action at the actuator
  - Start-up at the actuator
  - Settings made using the TROVIS-VIEW software

#### Options

- Faster motor
  - Double stroking speed possible (three-step version)
- Limit contacts
  - Two adjustable mechanical changeover switches
- Torque switches wired to terminals <sup>1)</sup>
  - Two non-floating switches
- Resistance transmitter
  - One resistance transmitter with a resistance range from 0 to 1000 Ω

<sup>1)</sup> In preparation



Fig. 1: Type 5827 Electric Actuator

#### Device code

Type ... Electric Actuator	5827	x	x	x
<b>Fail-safe action</b>				
Without		N		
Actuator stem extends		A		
Actuator stem retracts		E		
<b>Rated travel/adaptation</b>				
6 mm/force locking			1	
12 mm/force locking			2	
15 mm/form-fit			3	
<b>Control/supply voltage</b>				
Three-step control/230 V AC				1
Three-step control/24 V AC				2
Positioner/24 V AC and DC				4
Positioner/85 to 264 V AC				5

## Design and principle of operation

### ► Fig. 2

The actuator is mounted directly onto valves with force-locking connection with an M32x1.5 (width across flats 36). When the actuator stem extends, the actuator piston pushes against the valve's plug stem. When the actuator stem retracts, the plug stem is supported by a spring in the valve.

Valves with form-fit connection do not have a return spring. A yoke or adapter (see page 10 for accessories) is used to connect them to the actuator. The plug stem is moved by the actuator in both directions.

#### – Actuator without fail-safe action

The actuator without fail-safe action has a handwheel (2) used to manually position the valve. Travel and direction of action can be read off the travel indication scale (9).

#### – Actuator with fail-safe action

The electric actuator with fail-safe action largely corresponds to the version without fail-safe action described above. However, it contains a spring assembly (8) and an electromagnet, which move the connected valve to its fail-safe position when de-energized.

A handwheel (2) is not used. After the actuator is switched off and the front cover (1.1) removed, manual adjustment with an Allen key is possible. As soon as the Allen key is released, the actuator immediately moves back to its original position.

#### – Actuator stem extends

Upon supply voltage failure, the actuator stem extends.

#### – Actuator stem retracts

Upon supply voltage failure, the actuator stem retracts.

#### – Version with faster motor (three-step version)

The Types 5827-x11, -x21 and -x31 Actuators are equipped with a faster motor in a housing attached to the back of the actuator.

#### – Limit contacts

Optionally, the actuator can be equipped with two adjustable mechanical limit contacts. Optionally, the actuators can be equipped with two limit contacts, which are actuated by continuously adjustable cam disks.

The actuator with positioner is only available with adjustable limit contacts in the version for 24 V AC/DC supply voltage.

The two additional limit contacts are not suitable for retrofitting.

#### – Torque switches wired to terminals <sup>1)</sup>

The actuator version with three-step control can optionally be equipped with two fixed torque switches. They pass on the control signal after the end position is reached.

The two additional limit contacts are not suitable for retrofitting.

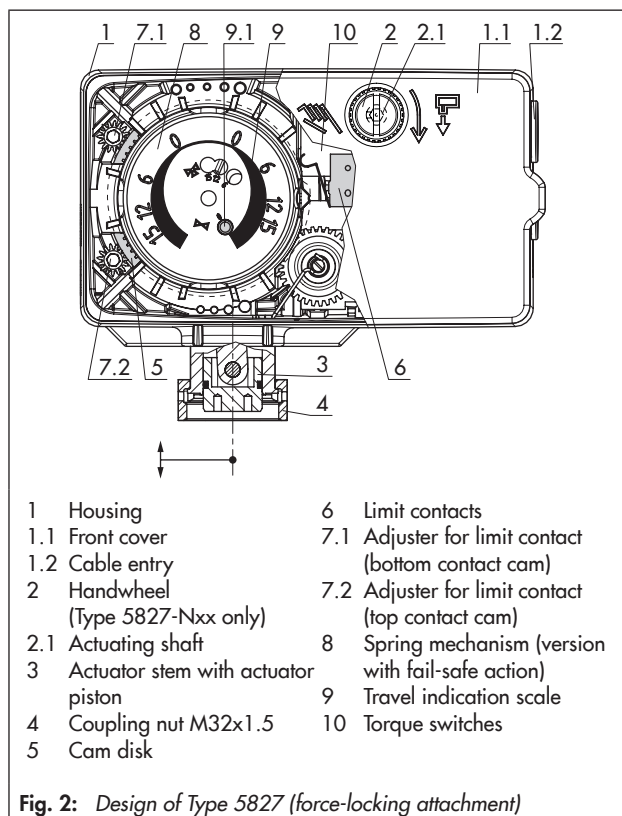

Fig. 2: Design of Type 5827 (force-locking attachment)

#### – Resistance transmitter (version with three-step signal)

The resistance transmitter is linked to the gear and produces a resistance signal between approx. 0 and 1000 Ω (usable range approx. 0 to 900 Ω) proportional to the valve travel. This version is always fitted with limit contacts as well.

#### – Version with digital positioner

The positioner ensures a predetermined assignment of the valve position to the input signal.

For position feedback, a 0 to 10 V signal can be picked off at terminals 32 and 33. The version with positioner allows the characteristic to be reversed and is suitable for split-range operation.

- Direction of action reversed by slide switch
- Momentary actuator travel calculated from transit time
- Operating status and errors indicated by LEDs
- Adjustable stroking speeds
- Blocking protection
- Adjustable input and output signal ranges
- Configuration, parameterization, diagnostic function and online connection for monitoring using the TROVIS-VIEW software
- Direct data transmission using a connecting cable (direct connection to computer)
- Data transmission over a memory pen

<sup>1)</sup> In preparation

## Settings

The digital positioner settings can be changed in the TROVIS-VIEW software.

**Table 1:** TROVIS-VIEW settings

Configuration	Default setting	Adjustment range
<b>Input variable</b>		
Lower range value	0 V 0 mA	0 to 7.5 V 0 to 15 mA
Upper range value	10 V 20 mA	2.5 to 10 V 5 to 20 mA
Unit	V	V/mA
<b>Position feedback signal</b>		
Lower range value	0.0 V	0.0 to 10.0 V
Upper range value	10.0 V	0.0 to 10.0 V
<b>Input signal</b>		
Detect input signal failure	No	Yes/No
Positioning value upon input signal failure	Internal	Internal/Last position
Internal positioning value	0.0 %	0.0 to 100.0 %
End position guiding when the value falls below the limit	1.0 %	0.0 to 49.9 %
End position guiding when the value exceeds the limit	97.0 %	50.0 to 100.0 %
<b>Functions</b>		
Blocking protection of valve	No	Yes/No
<b>Valve travel</b>		
Travel	100.0 %	30.0 to 130.0 %
Travel adjustment	Absolute	Absolute/Relative
Speed level	Standard	Slow/Standard/Fast
Dead band (switching range)	2.0 %	0.5 to 5.0 %
Characteristic	Linear	Linear/Equal percentage/Reverse equal percentage/User-defined

**Table 2:** Replacement of old actuators with new actuators (valve is retained)

Old actuator		New actuator	
Type	5824-10	Type	5827-N1x
	5824-13 <sup>1)</sup>		5827-N1x
	5824-20		5827-N2x
	5824-23 <sup>1)</sup>		5827-N2x
	5824-30		5827-N3x
	5824-33 <sup>1)</sup>		5827-N3x
	5825-10		5827-A1x
	5825-11 <sup>2)</sup>		5827-A1x
	5825-13 <sup>1)</sup>		5827-A1x
	5825-15		5827-E1x
	5825-20		5827-A2x
	5825-23 <sup>1)</sup>		5827-A2x
	5825-25		5827-E2x
	5825-30		5827-A3x
	5825-33 <sup>1)</sup>		5827-A3x
5825-35	5827-E3x		

- 1) Double stroking speed no longer covered by the type designation suffix
- 2) Actuator with slower motor no longer available; select actuator with standard stroking speed to replace it.

Three-step version

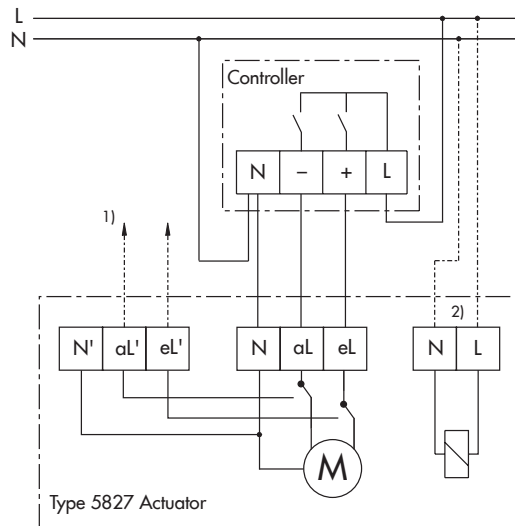

Additional electrical equipment

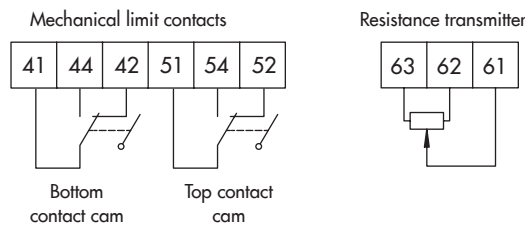

- 1) Signal feedforward for cascade control of several actuators after an actuator reaches its end position; "torque switch wired to terminals" version only
- 2) Only for Types 5827-A and 5827-E Actuators with fail-safe action

Version with digital positioner

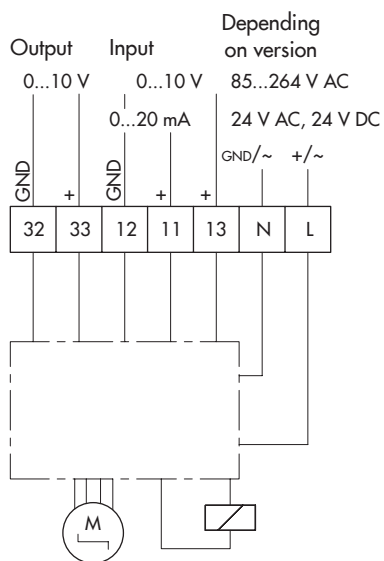

Additional electrical equipment  
Mechanical limit contacts (24 V version only)

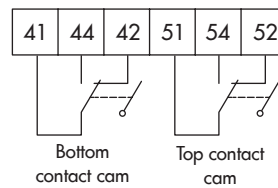

Fig. 3: Electrical connection

## Technical data

**Table 3:** Technical data · Type 5827-Nxx, version without fail-safe action

Type 5827-N			11	12	21	22	31	32	14	15	24	25	34	35
Actuation			Three-step						Positioner					
Rated travel mm			6 <sup>1)</sup>	6 <sup>1)</sup>	12	12	15	15	6 <sup>1)</sup>	6 <sup>1)</sup>	12	12	15	15
Thrust	Extends	N	700	700	700	700	700	700	700	700	700	700	700	700
	Retracts	N	–	–	–	–	700	700	–	–	–	–	700	700
Manual override			Yes											
Stroking speed <sup>2)</sup>	Slow	mm/s	–	–	–	–	–	–	0.13	0.13	0.13	0.13	0.13	0.13
	Standard	mm/s	0.18	0.18	0.18	0.18	0.18	0.18	0.2	0.2	0.2	0.2	0.2	0.2
	Fast	mm/s	0.36	–	0.36	–	0.36	–	0.36	0.36	0.36	0.36	0.36	0.36
Transit time for rated travel	Slow	s	–	–	–	–	–	–	45	45	89	89	111	111
	Standard	s	35	35	70	70	90	90	31	31	61	61	76	76
	Fast	s	18	–	35	–	45	–	17	17	33	33	41	41
Attachment	Force-locking		•	•	•	•	–	–	•	•	•	•	–	–
	Form-fit		–	–	–	–	•	•	–	–	–	–	•	•
Supply voltage														
24 V (±10 %), 50 Hz			–	•	–	•	–	•	–	–	–	–	–	–
230 V (±10 %), 50 Hz/60 Hz Protection provided by electrical installation in the building			•	–	•	–	•	–	–	–	–	–	–	–
24 V (±10 %), 50 and 60 Hz 24 V DC (–10, +20 %)			–	–	–	–	–	–	•	–	•	–	•	–
85 to 264 V, 50 and 60 Hz			–	–	–	–	–	–	–	•	–	•	–	•
Input signal			–						0 to 10 V, R <sub>i</sub> = 20 kΩ · 0 to 20 mA, R <sub>i</sub> = 50 Ω					
Output signal			–						0 to 10 V, R <sub>B</sub> = 1 kΩ					
Power consumption VA			3 <sup>3)</sup>	3	3 <sup>3)</sup>	3	3 <sup>3)</sup>	3	5 <sup>4)</sup>	8	5 <sup>4)</sup>	8	5 <sup>4)</sup>	8
Torque switch, active switching output <sup>5)</sup>			230 V, 1 A						–					
Weight kg			0.75 <sup>6)</sup>	0.75	0.75 <sup>6)</sup>	0.75	0.75 <sup>6)</sup>	0.75	0.75	0.75	0.75	0.75	0.75	0.75
Additional equipment <sup>7)</sup>														
Two limit contacts, max. 230 V, 1 A			•	•	•	•	•	•	•	–	•	–	•	–
One resistance transmitter <sup>8)</sup> , 0 to 1000 Ω ±15 %, max. 200 mW (90 % of final value at rated travel)			•	•	•	•	•	•	–	–	–	–	–	–

<sup>1)</sup> Actuators with 6 mm travel can also be used for valves with 7.5 mm travel (45 s transit time, 22.5 s for actuator with faster motor).

<sup>2)</sup> Adjustable in version with positioner

<sup>3)</sup> Double power consumption for version with faster motor

<sup>4)</sup> Power consumption of 24 V DC version specified in W

<sup>5)</sup> In preparation: only for version with "Torque switches wired to terminals"

<sup>6)</sup> The weight of the version with faster motor is 0.25 kg heavier.

<sup>7)</sup> Cannot be retrofitted

<sup>8)</sup> Only in combination with limit contacts; not possible in version with faster motor

**Table 4: Technical data · Type 5827-Axx, version with "actuator stem extends" fail-safe action**

Type 5827-A			11	12	21	22	31	32	14	15	24	25	34	35
Actuation			Three-step					Positioner						
Rated travel		mm	6 <sup>1)</sup>	6 <sup>1)</sup>	12	12	15	15	6 <sup>1)</sup>	6 <sup>1)</sup>	12	12	15	15
Thrust	Extends	N	500	500	500	500	280	280	500	500	500	500	280	280
	Retracts	N	–	–	–	–	280	280	–	–	–	–	280	280
Thrust in the event of fail-safe action		N	500	500	500	500	280	280	500	500	500	500	280	280
Manual override			Possible <sup>2)</sup>											
Stroking speed <sup>3)</sup>	Slow	mm/s	–	–	–	–	–	–	0.13	0.13	0.13	0.13	0.13	0.13
	Standard	mm/s	0.18	0.18	0.18	0.18	0.18	0.18	0.2	0.2	0.2	0.2	0.2	0.2
	Fast	mm/s	0.36	–	0.36	–	0.36	–	0.36	0.36	0.36	0.36	0.36	0.36
Transit time for rated travel	Slow	s	–	–	–	–	–	–	45	45	89	89	111	111
	Standard	s	35	35	70	70	90	90	31	31	61	61	76	76
	Fast	s	18	–	35	–	45	–	17	17	33	33	41	41
Transit time for rated travel in the event of fail-safe action		s	4	4	6	6	7	7	4	4	6	6	7	7
Attachment	Force-locking		•	•	•	•	–	–	•	•	•	•	–	–
	Form-fit		–	–	–	–	•	•	–	–	–	–	•	•
Supply voltage														
24 V (±10 %), 50 Hz			–	•	–	•	–	•	–	–	–	–	–	–
230 V (±10 %), 50 Hz/60 Hz Protection provided by electrical installation in the building			•	–	•	–	•	–	–	–	–	–	–	–
24 V (±10 %), 50 and 60 Hz 24 V DC (–10, +20 %)			–	–	–	–	–	–	•	–	•	–	•	–
85 to 264 V, 50 and 60 Hz			–	–	–	–	–	–	–	•	–	•	–	•
Power consumption		VA	5 <sup>4)</sup>	5	5 <sup>4)</sup>	5	5 <sup>4)</sup>	5	8 <sup>5)</sup>	10	8 <sup>5)</sup>	10	8 <sup>5)</sup>	10
Torque switch, active switching output <sup>6)</sup>			230 V, 1 A					–	–	–	–	–	–	–
Weight		kg	1 <sup>7)</sup>	1	1 <sup>7)</sup>	1	1 <sup>7)</sup>	1	1	1	1	1	1	1
Additional equipment <sup>8)</sup>														
Two limit contacts, max. 230 V, 1 A			•	•	•	•	•	•	•	–	•	–	•	–
One resistance transmitter <sup>9)</sup> , 0 to 1000 Ω ±15 %, max. 200 mW (90 % of final value at rated travel)			•	•	•	•	•	•	–	–	–	–	–	–
Testing according to DIN EN 14597			Yes											

<sup>1)</sup> Actuators with 6 mm travel can also be used for valves with 7.5 mm travel (45 s transit time, 22.5 s for actuator with faster motor).

<sup>2)</sup> Manual override with a 4 mm Allen key

<sup>3)</sup> Adjustable in version with positioner

<sup>4)</sup> Double power consumption for version with faster motor

<sup>5)</sup> Power consumption of 24 V DC version specified in W

<sup>6)</sup> In preparation: only for version with "Torque switches wired to terminals"

<sup>7)</sup> The weight of the version with faster motor is 0.25 kg heavier.

<sup>8)</sup> Cannot be retrofitted

<sup>9)</sup> Only in combination with limit contacts; not possible in version with faster motor

**Table 5: Technical data · Type 5827-Exx, version with "actuator stem retracts" fail-safe action**

Type 5827-E		11	12	21	22	31	32	14	15	24	25	34	35	
Actuation		Three-step						Positioner						
Rated travel		mm	6 <sup>1)</sup>	6 <sup>1)</sup>	12	12	15	15	6 <sup>1)</sup>	6 <sup>1)</sup>	12	12	15	15
Thrust	Extends	N	500	500	500	500	280	280	500	500	500	500	280	280
	Retracts	N	–	–	–	–	280	280	–	–	–	–	280	280
Thrust in the event of fail-safe action		N	–	–	–	–	280	280	–	–	–	–	280	280
Manual override		Possible <sup>2)</sup>												
Stroking speed <sup>3)</sup>	Slow	mm/s	–	–	–	–	–	–	0.13	0.13	0.13	0.13	0.13	0.13
	Standard	mm/s	0.18	0.18	0.18	0.18	0.18	0.18	0.2	0.2	0.2	0.2	0.2	0.2
	Fast	mm/s	–	–	–	–	–	–	0.36	0.36	0.36	0.36	0.36	0.36
Transit time for rated travel	Slow	s	–	–	–	–	–	–	45	45	89	89	111	111
	Standard	s	35	35	70	70	90	90	31	31	61	61	76	76
	Fast	s	–	–	–	–	–	–	17	17	33	33	41	41
Transit time for rated travel in the event of fail-safe action		s	4	4	6	6	7	7	4	4	6	6	7	7
Attachment	Force-locking		•	•	•	•	–	–	•	•	•	•	–	–
	Form-fit		–	–	–	–	•	•	–	–	–	–	•	•
Supply voltage														
24 V (±10 %), 50 Hz			–	•	–	•	–	•	–	–	–	–	–	–
230 V (±10 %), 50 Hz/60 Hz Protection provided by electrical installation in the building			•	–	•	–	•	–	–	–	–	–	–	–
24 V (±10 %), 50 and 60 Hz 24 V DC (–10, +20 %)			–	–	–	–	–	–	•	–	•	–	•	–
85 to 264 V, 50 and 60 Hz			–	–	–	–	–	–	–	•	–	•	–	•
Power consumption	VA		5	5	5	5	5	5	8 <sup>4)</sup>	10	8 <sup>4)</sup>	10	8 <sup>4)</sup>	10
Torque switch, active switching output <sup>5)</sup>			230 V, 1 A						–	–	–	–	–	–
Weight	kg		1	1	1	1	1	1	1	1	1	1	1	1
Additional equipment <sup>6)</sup>														
Two limit contacts, max. 230 V, 1 A			•	•	•	•	•	•	•	–	•	–	•	–
One resistance transmitter <sup>7)</sup> , 0 to 1000 Ω ±15 %, max. 200 mW (90 % of final value at rated travel)			•	•	•	•	•	•	–	–	–	–	–	–

<sup>1)</sup> Actuators with 6 mm travel can also be used for valves with 7.5 mm travel (45 s transit time, 22.5 s for actuator with faster motor).

<sup>2)</sup> Manual override with a 4 mm Allen key

<sup>3)</sup> Adjustable in version with positioner

<sup>4)</sup> Power consumption of 24 V DC version specified in W

<sup>5)</sup> In preparation: only for version with "Torque switches wired to terminals"

<sup>6)</sup> Cannot be retrofitted

<sup>7)</sup> Only in combination with limit contacts

**Table 6:** Technical data for all versions

Type 5827-N/-A/-E	All versions
Safety	
Degree of protection	IP 54 according to EN 60529 <sup>1)</sup>
Class of protection	II according to EN 61140
Degree of contamination	2 according to EN 60664-1
Noise immunity	According to EN 61000-6-2 and EN 61326-1
Noise emission	According to EN 61000-6-3 and EN 61326-1
Electrical safety	According to EN 60730-1 and EN 60730-2-14
Rated surge voltage	2.5 kV according to EN 60730-1
Vibration	According to EN 60068-2-64 and EN 60068-2-27
Conformity	
Materials	
Housing, housing cover	Plastic (PPO with glass fiber reinforcement)
Coupling nut M32x1.5	Brass
Ambient conditions	
Permissible temperature ranges <sup>2)</sup>	
Ambient	0 to 50 °C
Storage	-20 to +70 °C
Humidity	5 to 95 % moisture, no dew formation
Max. altitude above sea level	2000 m

<sup>1)</sup> Only with closed housing cover

<sup>2)</sup> The permissible medium temperature depends on the valve on which the actuator is mounted. The limits in the valve documentation apply.



**Force-locking attachment**

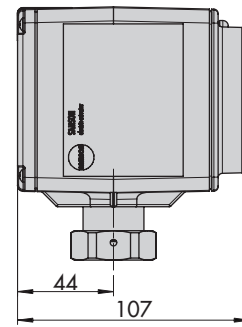
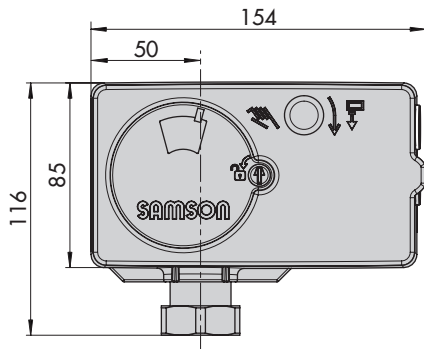

**Form-fit attachment**

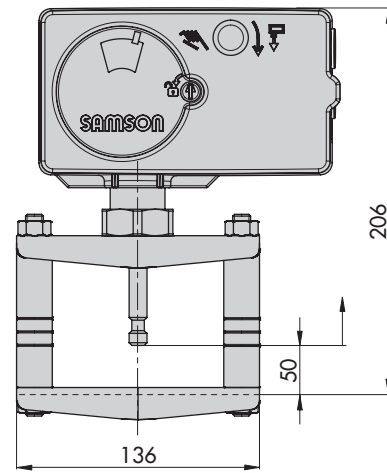
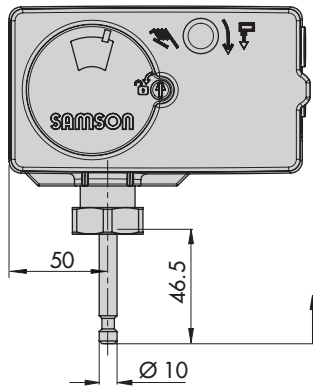

**Faster motor**

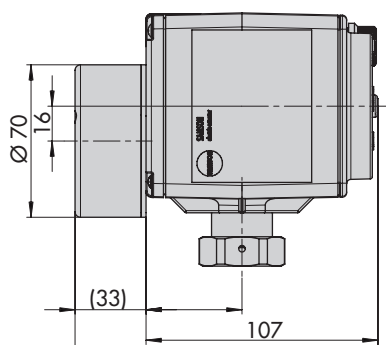
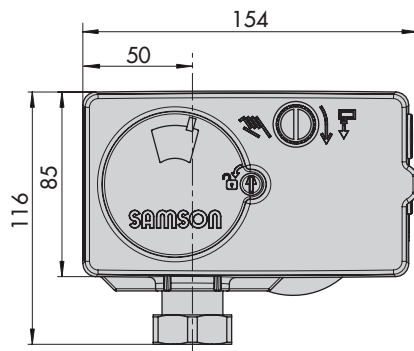

**Mounting orientation**

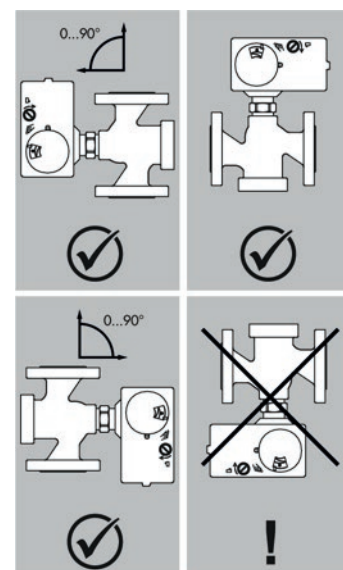

**Fig. 4:** Dimensions in mm and mounting position

## Accessories

For version with digital positioner	Order no.
Hardware package consisting of: <ul style="list-style-type: none"> <li>- Memory pen-64</li> <li>- Connecting cable</li> <li>- Modular adapter</li> </ul>	1400-9998
Memory pen-64	1400-9753
Connecting cable RJ-12/D-sub, 9 pin	1400-7699
Modular adapter D-sub 9-pin/RJ-12 for memory pen	1400-7698
USB to RS232 adapter	8812-2001
<b>Software</b>	
TROVIS-VIEW (free of charge)	► <a href="http://www.samsunggroup.com">www.samsunggroup.com</a> > SERVICE & SUPPORT > Downloads > TROVIS-VIEW
<b>For mounting on form-fit valves without return spring <sup>1)</sup></b>	<b>Order no.</b>
Yoke for Series V2001 Valves	1400-7414

<sup>1)</sup> With Type 5827-x3x Actuator

## Ordering text

Type 5827-... Electric Actuator

- Three-step version
  - Rated travel:
    - 6/12/15 mm
  - Standard/Fast
  - Supply voltage:
    - 230 V, 50 Hz
    - 230 V, 60 Hz (special version)
    - 24 V, 50 Hz
  - Torque switches wired to terminals: with/without
  - Limit contacts: with/without
  - Resistance transmitter: with/without
- Version with digital positioner
  - Rated travel:
    - 6/12/15 mm
  - Supply voltage:
    - 24 V, 50/60 Hz and DC
    - 85 to 264 V, 50 and 60 Hz
  - Limit contacts: with/without <sup>1)</sup>

<sup>1)</sup> 24 V version only

## Associated mounting and operating instructions

- Type 5827 (three-step version): ► **EB 5827-1**
- Type 5827 (version with positioner): ► **EB 5827-2**