

Data sheet

Wireless M-Bus inputs (In-A, In-B) 912.5/915/918.5 MHz

MULTICAL® 403

MULTICAL® 603

MULTICAL® 803

- Wireless M-Bus standard EN 13757-4:2019
- Configurable datagrams
- Up to 16 years battery lifetime
- Robust to interference
- Designed specific for USA and Canada

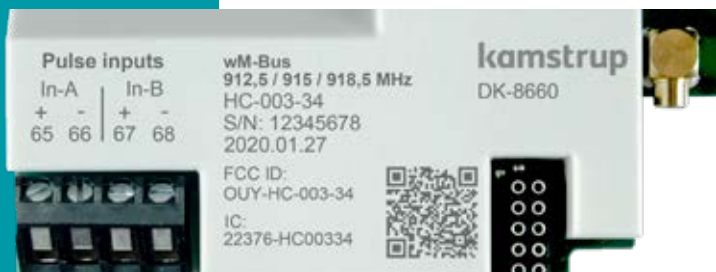

Contents

Introduction	3
Installation	3
Cable connections	4
Antenna	5
Wireless M-Bus datagrams	5
Technical data	6
Ordering	7
Configuration	7

Introduction

A high-performance M-Bus module has been introduced for the MULTICAL® 403, MULTICAL® 603 and MULTICAL® 803 energy meter family. A new design allows intensive reading of the meter without reducing the battery lifetime of the meter. The wM-Bus modules can be configured with multiple different datagrams, which enables you to adapt the read data to the actual application. The modules fulfil the requirements of the M-Bus standard EN 13757:2019

Applications

The module is designed with a focus on high flexibility to meet every conceivable application.

Analysis

MULTICAL® energy meters support large amounts of data and all analysis-relevant data can be read.

Billing

All data relevant to billing is supported in all meters

Emulation

With the configuration of datagrams, MULTICAL® 403,603 and 803 can emulate meters from different manufacturers.

Customized datagrams

With the flexibility of the wM-Bus modules, Kamstrup can offer our customers to customize the datagrams to their specific needs.

Installation

The module is easily mounted into a vacant module slot of the MULTICAL® 403, MULTICAL® 603 and MULTICAL® 803 .

Cable connections

Terminals

Max cable size 1.5 mm²

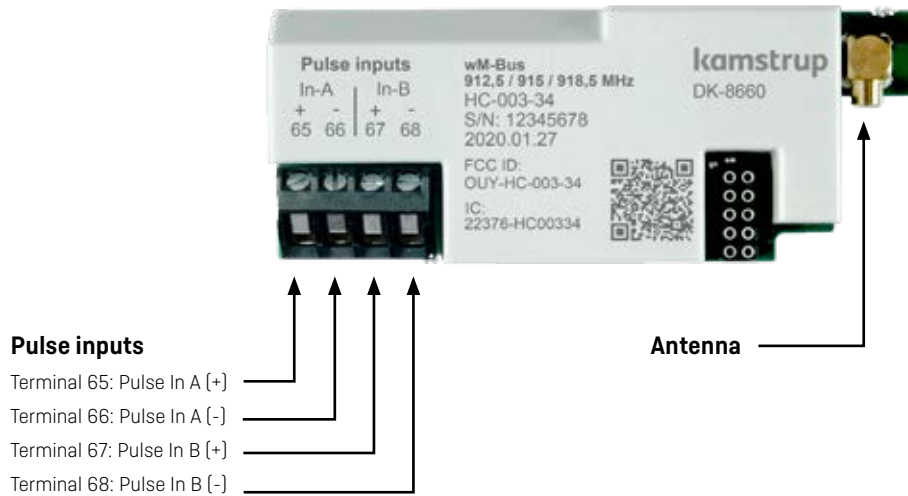

Pulse inputs

The module is equipped with two pulse inputs, In-A and In-B, to collect and accumulate pulses, e.g. from water and electricity meters.

The pulse inputs are physically placed on the module. However, the accumulation and logging of values are performed by the MULTICAL® calculator.

When installing a module with pulse inputs in slot 2 of MULTICAL® 603 and MULTICAL® 803, the pulse inputs will be registered in the meter as In-A2 and In-B2.

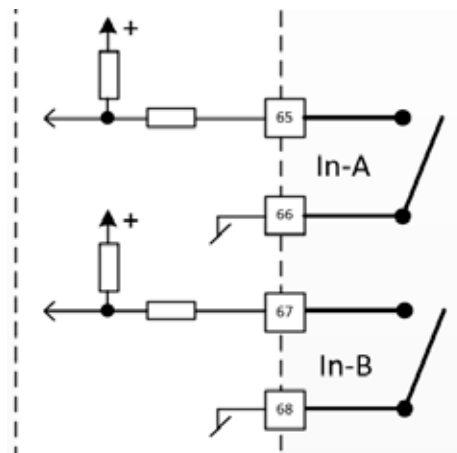

Antenna



This radio-based module must have either an internal or external antenna connected.

When mounting an external antenna please ensure that the antenna cable is arranged in such a manner that damage of the cable is prevented when the meter is assembled.

Wireless M-Bus datagrams

The Wireless M-Bus modules can be used in all MULTICAL® 403, MULTICAL® 603 and MULTICAL® 803.

Note, however, that there are MULTICAL® 803 registries that are not available in MULTICAL® 403 and 603, and some registers that are in MULTICAL® 603 are not available in MULTICAL® 403. Likewise, the meter configuration influences which registers are available. If the meter does not have the relevant register, the module will simply refrain from sending this register.

The datagram can be changed using the USB configuration cable via METERTOOL.

Examples of datagrams:

34-10-101: C1, Drive-by, Standard registers	34-10-102: C1, Drive-by, Alternative registers
Heat energy E1	Heat energy E1
Cooling energy E3	Cooling energy E3
Cooling energy E3	Cooling energy E3
Energy E8	Energy E8
Energy E9	Energy E9
Volume V1	Volume V1
Flow V1 actual	Pulse input A1
t1 actual [2 decimals]	Pulse input B1
t2 actual [2 decimals]	Flow V1 actual
Info bits	t1 actual
Date	t2 actual
Heat energy E1	Power max year
Cooling energy E3	Tariff TA2
Cooling energy E3	Tariff TA3
Volume V1	Infobits
Date	Date
	Heat energy E1
	Cooling energy E3
	Cooling energy E3
	Volume V1
	Pulse input A1
	Pulse input B1
	Date

Technical data

Physical

For installation in MULTICAL® 403, MULTICAL® 603 and MULTICAL® 803.

Mechanical data

Dimensions (L x W x D) 90 x 35 x 14 mm
Weight < 45g.

MULTICAL® Supply

 Battery or AC supply

Data refresh rate

Data from the meter to the module are refreshed each time the meter completes an integration. Integration mode is defined by the meters L-code.

Radio communication

Transmit frequency 912.5/915/918.5 MHz
Protocol Wireless M-Bus, C- and T-mode, EN 13757-4:2013
Transmission interval 16 seconds.
Transmission power 25 mW
Range Internal antenna <300 m
External antenna <600 m

Pulse inputs

Input type Contact input
Open voltage 3.6 V
Current $\leq 5\mu\text{A}$
Max cable length 10 m

Environment

Operational temperature 5 °C – 55 °C
Humidity 25 – 85 % RH non-condensing

Compatibility

EN13757 M-Bus standard

Programming

Configuration/ Firmware Via the multipole connector on the module using METERTOOL HCW.
C2 via READY Converter

Battery lifetime

Expected 16 Years (D-Cell)
Depends on selected module configuration

Ordering

Description	Order No.
wM-Bus, inputs (In-A, In-B),912,5/915/918,5 MHz	HC-003-34
Internal Antenna	6699 482
External Antenna, Mini-Triangel	6699 448
USB Configuration cable for H/C-modules	6699 035
Infrared optical readout head w/USB	6699 099
METERTOOL HCW	www.kamstrup.com
USB Meter Reader	www.kamstrup.com
READY	www.kamstrup.com

Configuration

	XX	YY	ZZZ
Product type of module			
Wireless M-Bus, inputs (In-A, In-B),912.5/915/918.5 MHz	34	00	100
System configuration			
C1, 16 s interval, 25 mW, Walk-by/Drive-by, Frame format B		10	
Datagram			
C1, Drive-by, Standard registers			101
C1, Drive-by, Alternative registers			102

This list of datagrams is not complete, as new datagrams are added regularly.

Wireless M-Bus inputs (In-A, In-B), 912.5/915/918.5 MHz

MULTICAL® 403
MULTICAL® 603
MULTICAL® 803

Kamstrup A/S • 58101790_B1_US_07.2022

Kamstrup A/S
Industrivej 28, Stilling
DK-8660 Skanderborg
T: +45 89 93 10 00
info@kamstrup.com
kamstrup.com